

Features

- Integral porting adapter for simple single or double outlet conversion, thus providing reduced stock by eliminating external crossports and singling bars.
- Air bleed valves built into base
- SAE Metric – BSP – NPTF threads available
- Operates up to 500 bar (7.200 PSI)
- Operates with Oil or Grease
- Full monitoring controls
- The components are zinc-plated
- The bases are always supplied complete with standard 'O' rings and fixing screws

Advantages

- Conventional tie rods are eliminated. There is no maximum limitation on the number of elements which can be used on the assembly.
- Auxiliary by-pass elements can be installed in the assembly to accommodate an increase or decrease in points without disturbing the base assembly or pipework
- Lubricant volume can be easily increased or decreased during system commissioning or service without disturbing the base assembly or pipework

Modular progressive distributors SMO-SMX

Easy and flexible assembly and low cost maintenance



The modular system consists of two main components: the base and the metering elements.

The modular progressive distributor is available in two sizes: SMO miniature and SMX standard.

Conventional bridging pieces are eliminated. Bridging elements have been introduced and these interconnect and discharge into the adjacent element.

The distributor assembly

principle enables factory floor distributor assembly to accommodate grouping of lubrication points.

The base assembly can be mounted and piped up without the metering elements. This provides the most advantageous routing of pipe work and the elements can then be fitted to suit.

The system can be easily extended and the modular concept provides low cost replacement of component.

Delivery and Dimensions

SMX METERING ELEMENTS			
DELIVERY PER OUTLET		1 OR 2 OUTLETS	
CC.	CU. IN.	Symbol	Part No.
.04	.0024	SMX 04	641825
.08	.005	SMX 08	641516
.16	.010	SMX 16	641517
.25	.015	SMX 25	641518
.35	.021	SMX 35	641519
.40	.025	SMX 40	641520
.50	.030	SMX 50	641521
.60	.036	SMX 60	641522
.65	.040	SMX 65	641523
.00	.000	BY PASS X	641514

SMO METERING ELEMENTS			
DELIVERY PER OUTLET		1 OR 2 OUTLETS	
CC.	CU. IN.	Symbol	Part No.
.04	.0024	SMO 04	641720
.08	.005	SMO 08	641716
.16	.010	SMO 16	641717
.25	.015	SMO 25	641718
.00	.000	BY PASS 0	641714

SMO - SMX DIMENSIONS								
Type	A		B		C		D	
	mm	in	mm	in	mm	in	mm	in
SMO	18.5	0.72	16	0.62	20.60	0.80	30	1.17
SMX	20	0.78	20.2	0.78	23.42	0.91	35	1.36
	E		F		G			
	mm	in	mm	in	mm	in		
SMO	12.5	0.72	30	1.17	50	1.9		
SMX	12.5	0.72	30	1.17	56	2.2		

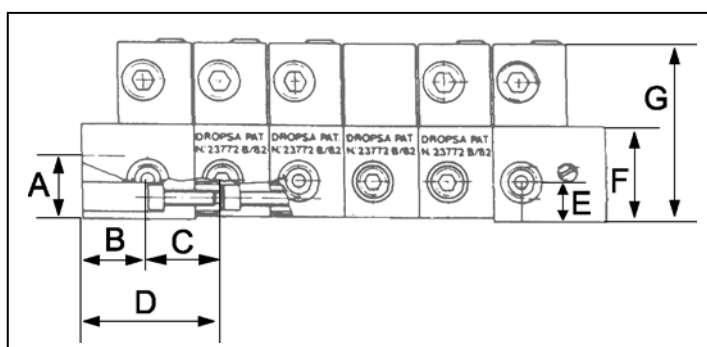

SMO - SMX DIMENSIONS								
Type	SMO				SMX			
	A		B		A		B	
No. Elements	mm	in	mm	in	mm	in	mm	in
3	80,2	3.1	71,8	2.8	93,02	3.6	83,02	3.2
4	100,8	3.9	92,4	3.6	116,44	4.5	106,44	4.1
5	121,4	4.7	113,0	4.4	139,86	5.4	129,86	5.1
6	142,0	5.5	133,6	5.2	163,28	6.4	153,28	6.1
7	162,6	6.3	154,2	6.1	186,70	7.2	176,70	6.9
8	183,2	7.1	174,8	6.8	210,12	8.2	200,12	7.8
9	203,8	7.9	195,4	7.6	233,53	9.1	223,53	8.7
10	224,4	8.7	216,0	8.4	256,95	10.1	246,95	9.6
11	245,0	9.5	236,6	9.2	280,37	10.9	270,37	10.5
12	265,6	10.3	257,8	10.1	303,79	11.8	293,79	11.4
13	286,2	11.1	277,8	10.8	327,21	12.8	317,21	12.4
14	306,8	12.1	298,4	11.6	350,63	13.7	340,63	13.3
15	327,4	12.8	319,0	12.4	374,05	14.6	364,05	14.2
16	348,0	13.6	339,6	13.2	397,47	15.5	387,47	15.1
17	368,6	14.4	360,2	14.1	420,89	16.4	410,89	16.1
18	389,2	15.2	380,8	14.8	444,30	17.3	434,30	16.9
19	409,8	16.1	401,4	15.6	467,72	18.2	457,72	17.8
20	430,4	16.8	422,0	16.4	491,14	19.1	481,14	18.8

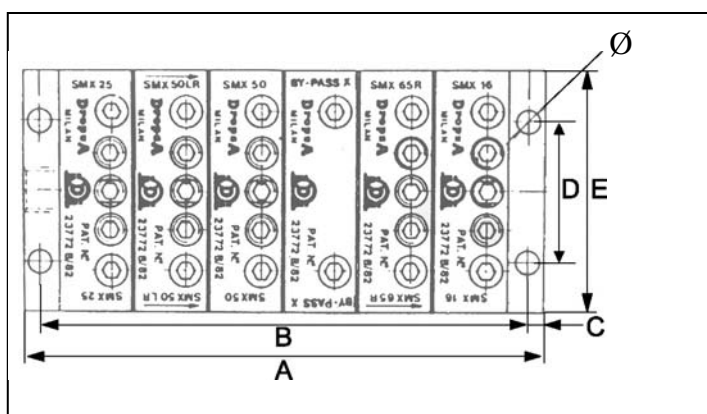

SMO - SMX DIMENSIONS							
Type	C		D		E		Ø
	mm	in.	mm	in.	mm	in.	
SMO	4,2	0.16	42	1.63	68	2.6	6
SMX	5,0	2	44,45	1.73	76	2.9	7.2

Principles of operation

1. The flow of lubricant reaches all the elements and pushes all the metering pistons towards the right

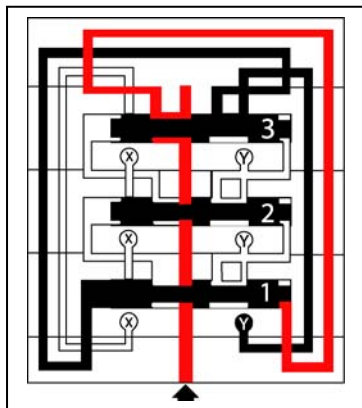

2. Successively, the flow pushes on the right side of the first piston

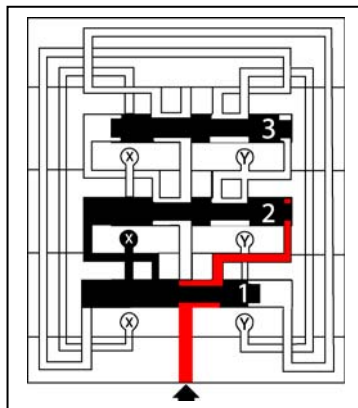

3. The first piston, having moved to the left inverts the direction of the flow so that all the other pistons are moved to the left

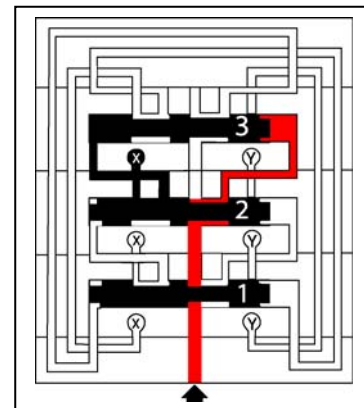

The continuing flow pushes the first piston towards the right, changing the system to the conditions in Fig.1. The progressive movement of the pistons discharges from the outlets X and Y the lubricant accumulated in the previous sequence.

The base

The base is made up of a minimum of three segments:

- Inlet base
- Intermediate base
- End Base

And can be increased in unlimited number by addition of intermediate sections.

This revolutionary system makes the assembly easy and flexible; there is no need to determine in advance the size of the base, just add on distributors in unlimited number by means of very simple threaded inserts supplied for the assembly (Patented).

This simple technique allows the system to operate even at very high pressure without any leakage in the assembly.

There is also the possibility of ordering with one part number only, the end base + the intermediate base already assembled. Simply add on the inlet base and you have a three base assembly.

With just 3 screws!

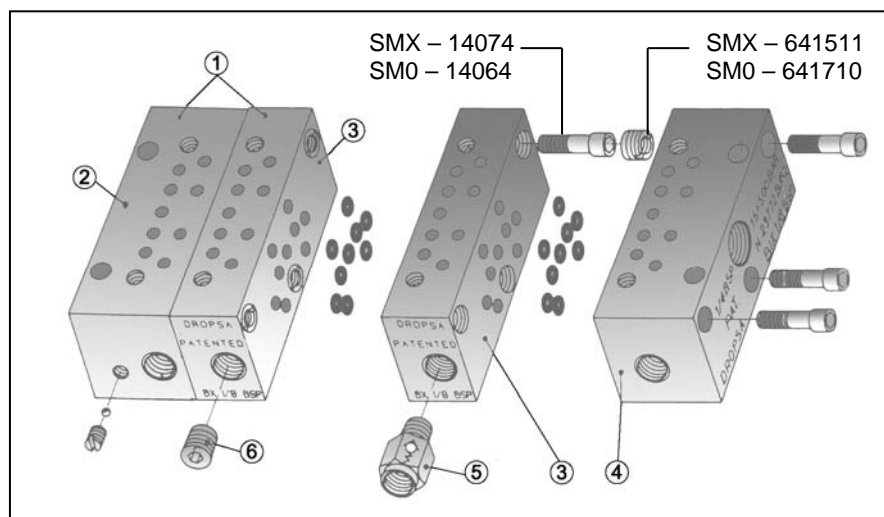

Ref.	Description	SMO		SMX			SYMBOL	
		1/8 BSP	1/8 NPTF	1/4 BSP	1/4 NPTF	7/16-20 UNF		
	Inlet Thread →	1/8 BSP	1/8 NPTF	1/4 BSP	1/4 NPTF	7/16-20 UNF	SYMBOL	
	Outlet Thread →	1/8 BSP	1/8 NPTF	1/8 BSP	1/8 NPTF	7/16-20 UNF		
1	End Base + intermediate base	641792	643569	641561	643568	642028		
2	End Base	641713	643564	BF0	641515	643561	643802	BFX
3	Intermediate base	641712	643563	B0	641513	643542	643801	BX
4	Inlet base	641711	643562	BI0	641512	643541	643800	BIX
5	Check Valve	92335	641564		92335	641564	642029	
6	Plug	3232098	3232095		3232098	3232095	642031	

Contacts

www.dropsa.com
sales@dropsa.com

ITALIA

Dropsa SpA
 t. +39 02-250791
 f.+39 02-25079767

U.K.

Dropsa (UK) Ltd
 t. +44 (0)1784-431177
 f. +44 (0)1784-438598

GERMANY

Dropsa GmbH
 t. +49 (0)211-394-011
 f. +49 (0)211-394-013

FRANCE

Dropsa Ame
 t. +33 (0)1-3993-0033
 f. +33 (0)1-3986-2636

ESPAÑA

Polydrop, S.A.
 t. +34 (0)93-260-22-50
 f. +34 (0)93-260-22-51

U.S.A.

Dropsa Corporation
 t. +1 586-566-1540
 f. +1 586-566-1541

AUSTRALIA

Dropsa Australia Ltd.
 t. +61 (0)2-9938-600644
 f. +61 (0)2-9938-6611

BRAZIL

Dropsa
 t. +55 (0)11-563-10007
 f. +55 (0)11-563-19408

Dealer:

C2104PE WK25/05

Order Example

**SMO – 6 (MO8 – M16LR – M25CC
 – M08D – M25R – M25C)**

Note: the assembly is seen vertically and the outlets are in sequence; starting from the bottom (inlet) from left to right. Symbol 'LR' refers to bridge elements.

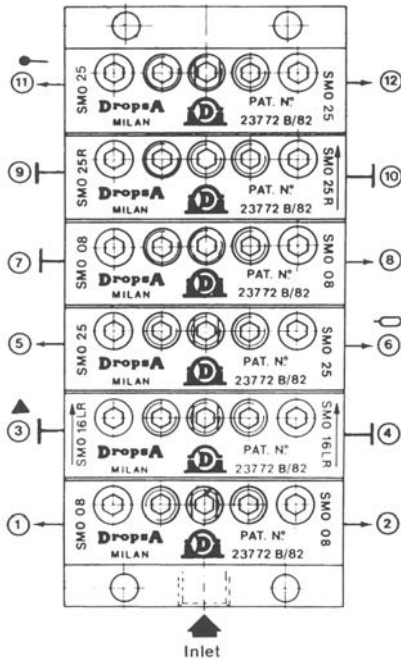

Single and double outlet conversion

It is possible to double the delivery of a single element by replacing the Yellow Adapter Part. No. 641709 with the White adapter Part. No. 641708 as shown in the drawing.

When converted into single, plug off the second outlet.

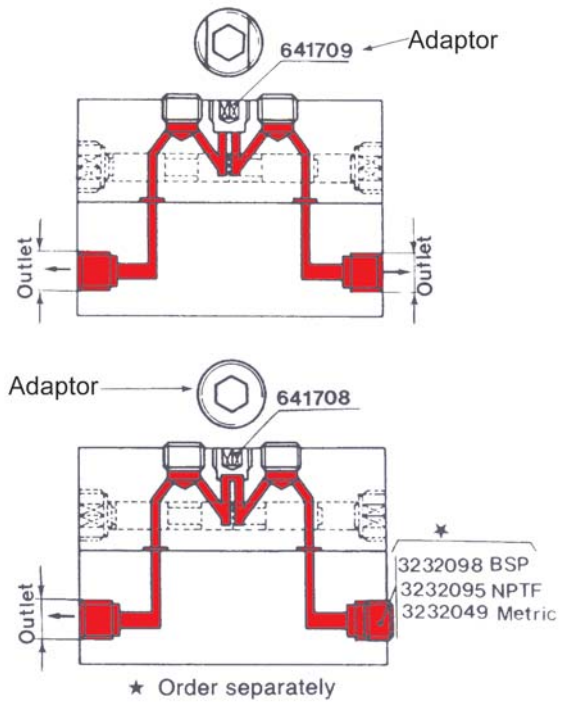

How to order

