

System 33V

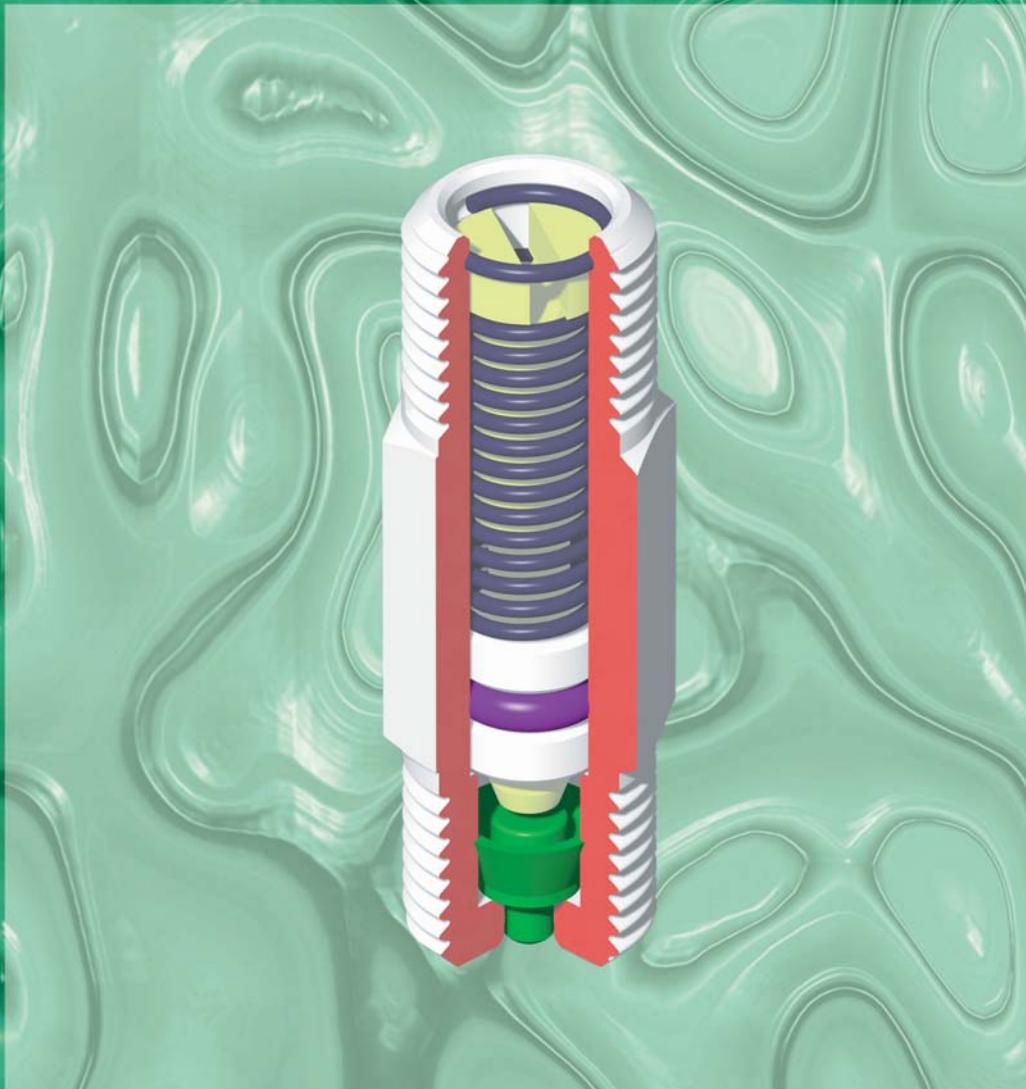

**Positive Displacement
Injector
for Oil and Fluid Grease**



Positive Displacement Injector

Automatic Lubrication Systems

GB
USA

Index

Operating Characteristics and specification	3
Introduction – Operating Principle	4
Example application	5
Rotary connection	5
Injectors for Manifold Mounting	6
Injectors for Bearing Mounting	7
Manifolds – 33V Fixtures Type M,L,P,N (aluminium)	9
Extruded Profile bars for Custom Manifolds	9
Manifold - Type W : for Backward Compatibility with existing systems (aluminium)	10
Manifold – Stainless steel AISI 304	11
Manifold – for DIN 3852 Fittings (aluminium)	11
Metalling tube	12
Nylon tube	12
Pipe clips	12
Nylon hoses with reusable fittings	13
Special hoses	13
High pressure Push-In for oil and grease	14
Fitting structures abbreviations	15

Product Features :

- Compatible and Interchangeable with Dropsa’s Accumino and Dromatic System
- More compact design. 1/8”-1/8” BSP injector cartridge allows many new configurations.
- High Reliability. The 33V Injector is fully assembled, tested and certified on a robotic system.
- Manifolds for compatibility with other systems.

Operating Characteristics:

		Delivery		
		0.03 – 0.16	0.20 – 0.50	0.75 – 1.00
Minimum pressure bar (psi)		12 (175)	12 (175)	12 (175)
Maximum pressure bar (psi)		50 (725)	50 (725)	50 (725)
Maximum pressure of release bar (psi) **		4 (58)	2.5 (36)	2.5 (36)
Lubricant	Oil	32-2000 cSt	32-2000 cSt	32-2000 cSt
	Grease	NLGI 0	/	/
Minimum time of release (seconds) *	32-250 cSt	10	10	10
	260-1000 cSt	200	200	200
	NLGI 0	200	/	/

* Minimum time of release depending on the specifics of the systems where V33 injector are mounted.
If they need to be assembled on medium or large – sized systems, please contact Dropsa’s technical – commercial department to check their real time of release

** Point delivery

Introduction – Operating Principle of the V33 Injector Series

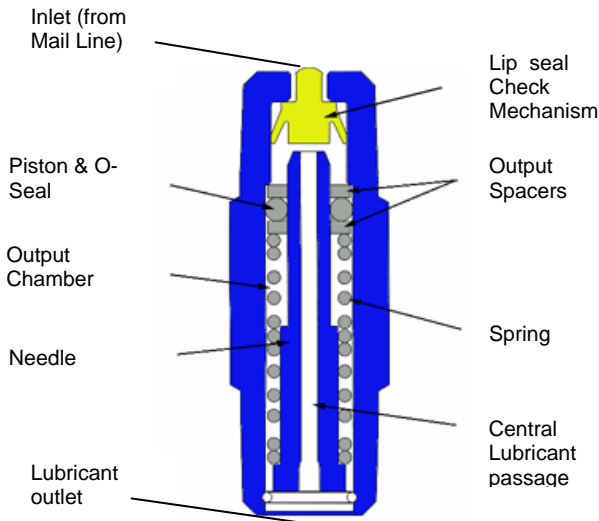

The system is pressurized and oil flows into the Inlet side of the injector. The Lip seal check mechanism allows oil to flow past blocking off the Central Lubricant Passage.

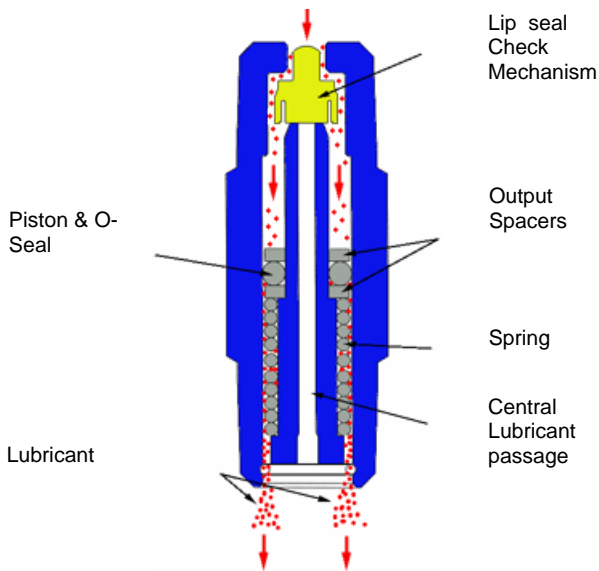

Lubricant enters the upper chamber of the injector which causes the Piston & O-Seal to move downwards pushing the oil accumulated in the Output chamber (from the previous cycle) towards the lubrication point.

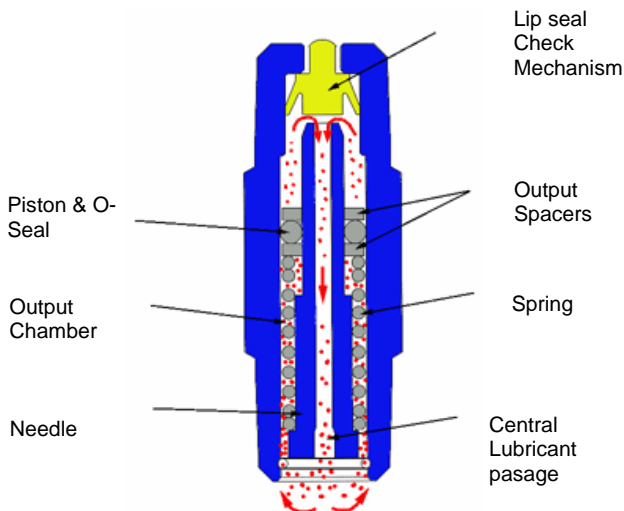

The final stage occurs when Pressure is released from the Inlet resetting the injector. During this phase the Spring pushes the piston & O-Seal back upwards, together with the check mechanism that permits the lubricant to flow across the Central Lubricant Passage and back into the Output Chamber, ready for the next lubrication cycle.

Example Application Using Smart Pump and 33 Valves.

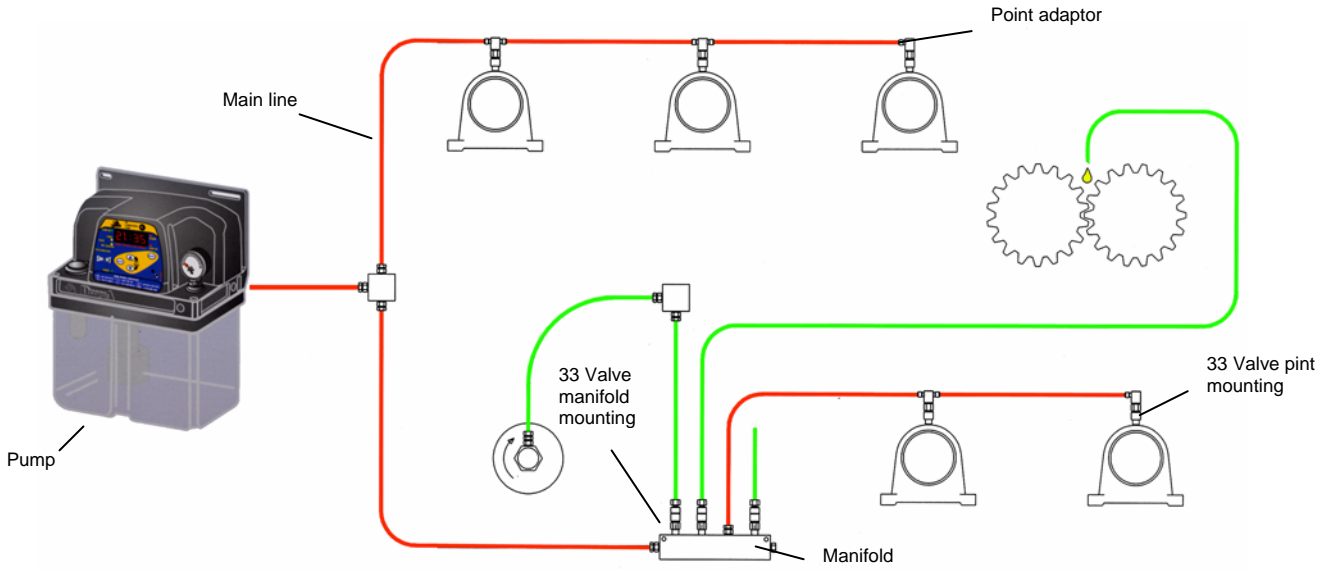

Point Adaptor Assembly Example.

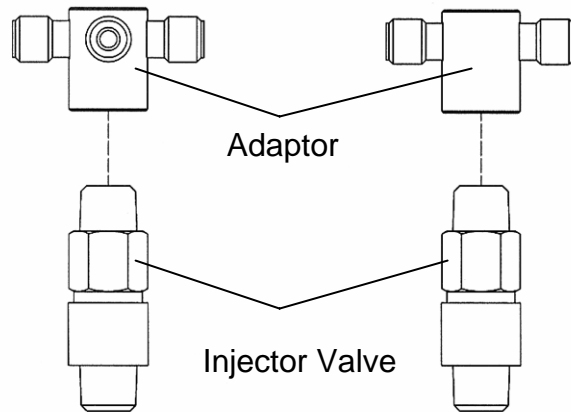

Rotary Connection Application

No. Revolutions per min. 100 - No. Oscillations per min. 120

90° Rotary		Straight Rotary																	
<p>rotary Part No. 936035</p> <p>1/8 BSPT</p> <p>30</p> <p>1/8 BSPT taper</p> <p>spacer Part No. 936020</p> <p>metering valve</p>		<p>Part No. 936045</p> <p>1/8 BSPT</p> <p>30</p> <p>1/8 BSPT</p>	<table border="1"> <thead> <tr> <th colspan="4">Rotary p/n 0936035</th> </tr> <tr> <th>Connector</th> <th>Compr. cone</th> <th>Bushing</th> <th>Pipe o/d</th> </tr> </thead> <tbody> <tr> <td>0910073</td> <td>0093004</td> <td>0092004</td> <td>4</td> </tr> <tr> <td>0910090</td> <td>0093006</td> <td>0092052</td> <td>6</td> </tr> </tbody> </table>	Rotary p/n 0936035				Connector	Compr. cone	Bushing	Pipe o/d	0910073	0093004	0092004	4	0910090	0093006	0092052	6
Rotary p/n 0936035																			
Connector	Compr. cone	Bushing	Pipe o/d																
0910073	0093004	0092004	4																
0910090	0093006	0092052	6																

33V – System 33 Injectors

Injectors for Manifold Mounting

Output: 0.03 to 0.50 cc/cycle.

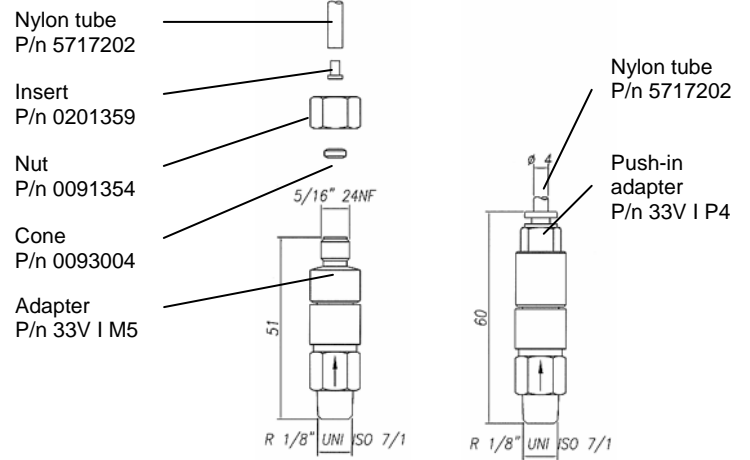

Output/Cycle	Part Num.	Part Number (Body AISI 316L)	Compatible Manifold Type	With pre-assembled Output Adaptor		
				Male Thread	Push-in for 4mm Tube	Push-in for 4mm Tube (Body AISI 316L)
0.03	33V 003	33V 003X	M, P, L, N, W	33V I M5 003	33V I P4 003	33V I P4 003X
0.06	33V 006	33V 006X		33V I M5 006	33V I P4 006	33V I P4 006X
0.10	33V 010	33V 010X		33V I M5 010	33V I P4 010	33V I P4 010X
0.16	33V 016	33V 016X		33V I M5 016	33V I P4 016	33V I P4 016X
0.20	33V 020		M, P, L, N	33V I M5 020	33V I P4 020	
0.30	33V 030			33V I M5 030	33V I P4 030	
0.50	33V 050			33V I M5 050	33V I P4 050	

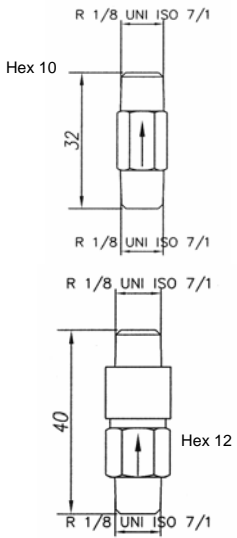

Output: 0,75 to 1.00 cc/cycle

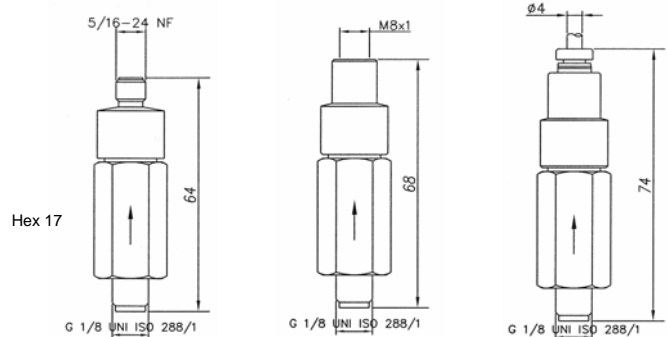

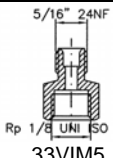
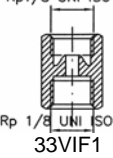

Output/Cycle	Compatible Manifolds	Output Porting		
		Male Thread	Female M8x1 Thread	Push-in for 4mm Tube
0.75	L, N	33V I M5 075	33V I F8 075	33V I P4 075
1.00		33V I M5 100	33V I F8 100	33V I P4 100

Injectors for application directly to Lubrication point

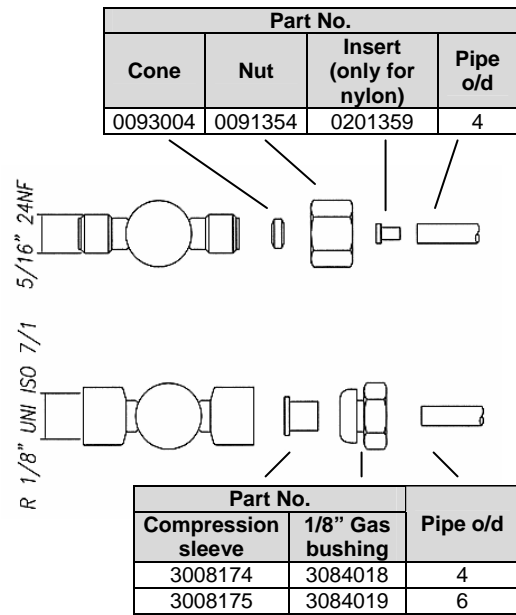

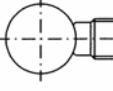
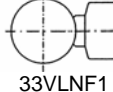
Straight Adapter	Pre assembled with Injector		
	Output	Male	Female
 5/16" 24NF Rp 1/8 UNI ISO 7/1 33VIM5	0.03 cc	33V IS M5 003	33V IS F1 003
	0.06 cc	33V IS M5 006	33V IS F1 006
 Rp1/8 UNI ISO 7/1 Rp 1/8 UNI ISO 7/1 33VIF1	0.10 cc	33V IS M5 010	33V IS F1 010
	0.16 cc	33V IS M5 016	33V IS F1 016
	0.20 cc	33V IS M5 020	33V IS F1 020
	0.30 cc	33V IS M5 030	33V IS F1 030
Side View	0.50 cc	33V IS M5 050	33V IS F1 050

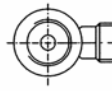

L Adapter	Pre assembled with Injector		
Output	Male	Female	
 33VLNM5	0.03 cc	33V LN M5 003	33V LN F1 003
	0.06 cc	33V LN M5 006	33V LN F1 006
	0.10 cc	33V LN M5 010	33V LN F1 010
 33VLNF1	0.16 cc	33V LN M5 016	33V LN F1 016
	0.20 cc	33V LN M5 020	33V LN F1 020
	0.30 cc	33V LN M5 030	33V LN F1 030
	0.50 cc	33V LN M5 050	33V LN F1 050
Top View			

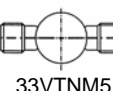
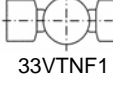

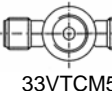
L Adapter with Rotary connection Port	Pre assembled with Injector		
Output	Male	Female	
 33VLCM5	0.03 cc	33V LC M5 003	33V LC F1 003
	0.06 cc	33V LC M5 006	33V LC F1 006
	0.10 cc	33V LC M5 010	33V LC F1 010
 33VLCF1	0.16 cc	33V LC M5 016	33V LC F1 016
	0.20 cc	33V LC M5 020	33V LC F1 020
	0.30 cc	33V LC M5 030	33V LC F1 030
	0.50 cc	33V LC M5 050	33V LC F1 050
Top View			

T Adapter	Pre assembled with Injector		
Output	Male	Female	
 33VTNM5	0.03 cc	33V TN M5 003	33V TN F1 003
	0.06 cc	33V TN M5 006	33V TN F1 006
	0.10 cc	33V TN M5 010	33V TN F1 010
 33VTNF1	0.16 cc	33V TN M5 016	33V TN F1 016
	0.20 cc	33V TN M5 020	33V TN F1 020
	0.30 cc	33V TN M5 030	33V TN F1 030
	0.50 cc	33V TN M5 050	33V TN F1 050
Top View			

T Adapter with Rotary connection Port	Pre assembled with Injector		
Output	Male	Female	
 33VTCM5	0.03 cc	33V TC M5 003	33V TC F1 003
	0.06 cc	33V TC M5 006	33V TC F1 006
	0.10 cc	33V TC M5 010	33V TC F1 010
 33VTCF1	0.16 cc	33V TC M5 016	33V TC F1 016
	0.20 cc	33V TC M5 020	33V TC F1 020
	0.30 cc	33V TC M5 030	33V TC F1 030
	0.50 cc	33V TC M5 050	33V TC F1 050
Top View			

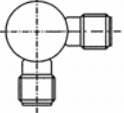
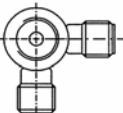
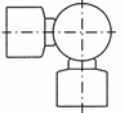
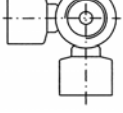
Injectors for application directly to Lubrication point

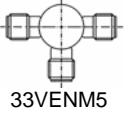
C Adapter		Pre assembled with Injector		C Adapter with Rotary connection Port		Pre assembled with Injector	
	Output	Male	Female		Output	Male	Female
 33VCNM5	0.03 cc	33V CN M5 003	33V CN F1 003	 33VCCM5	0.03 cc	33V CC M5 003	33V CC F1 003
	0.06 cc	33V CN M5 006	33V CN F1 006		0.06 cc	33V CC M5 006	33V CC F1 006
	0.10 cc	33V CN M5 010	33V CN F1 010		0.10 cc	33V CC M5 010	33V CC F1 010
 33VCNF1	0.16 cc	33V CN M5 016	33V CN F1 016	 33VCCF1	0.16 cc	33V CC M5 016	33V CC F1 016
	0.20 cc	33V CN M5 020	33V CN F1 020		0.20 cc	33V CC M5 020	33V CC F1 020
	0.30 cc	33V CN M5 030	33V CN F1 030		0.30 cc	33V CC M5 030	33V CC F1 030
	0.50 cc	33V CN M5 050	33V CN F1 050		0.50 cc	33V CC M5 050	33V CC F1 050

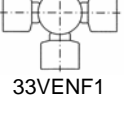
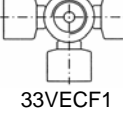
E Adapter		Pre assembled with Injector		E Adapter with Rotary connection Port		Pre assembled with Injector	
	Output	Male	Female		Output	Male	Female
 33VENM5	0.03 cc	33V EN M5 003	33V EN F1 003	 33VECM5	0.03 cc	33V EC M5 003	33V EC F1 003
	0.06 cc	33V EN M5 006	33V EN F1 006		0.06 cc	33V EC M5 006	33V EC F1 006
	0.10 cc	33V EN M5 010	33V EN F1 010		0.10 cc	33V EC M5 010	33V EC F1 010
 33VENF1	0.16 cc	33V EN M5 016	33V EN F1 016	 33VECF1	0.16 cc	33V EC M5 016	33V EC F1 016
	0.20 cc	33V EN M5 020	33V EN F1 020		0.20 cc	33V EC M5 020	33V EC F1 020
	0.30 cc	33V EN M5 030	33V EN F1 030		0.30 cc	33V EC M5 030	33V EC F1 030
	0.50 cc	33V EN M5 050	33V EN F1 050		0.50 cc	33V EC M5 050	33V EC F1 050

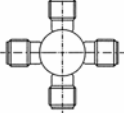
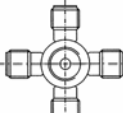
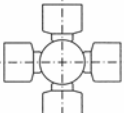
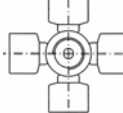
X Adapter		Pre assembled with Injector		X Adapter with Rotary connection Port		Pre assembled with Injector	
	Output	Male	Female		Output	Male	Female
 33VXNM5	0.03 cc	33V XN M5 003	33V XN F1 003	 33VXCM5	0.03 cc	33V XC M5 003	33V XC F1 003
	0.06 cc	33V XN M5 006	33V XN F1 006		0.06 cc	33V XC M5 006	33V XC F1 006
	0.10 cc	33V XN M5 010	33V XN F1 010		0.10 cc	33V XC M5 010	33V XC F1 010
 33VXNF1	0.16 cc	33V XN M5 016	33V XN F1 016	 33VXCF1	0.16 cc	33V XC M5 016	33V XC F1 016
	0.20 cc	33V XN M5 020	33V XN F1 020		0.20 cc	33V XC M5 020	33V XC F1 020
	0.30 cc	33V XN M5 030	33V XN F1 030		0.30 cc	33V XC M5 030	33V XC F1 030
	0.50 cc	33V XN M5 050	33V XN F1 050		0.50 cc	33V XC M5 050	33V XC F1 050

Manifolds – V33 Fixtures Type M, P, L, N (Aluminium)

Single Row

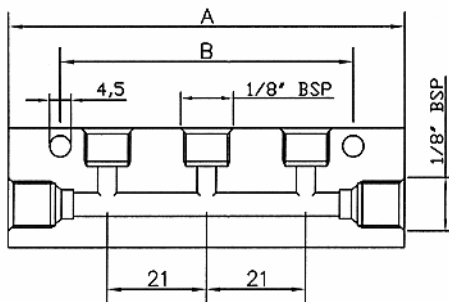

For Injectors 0.03 – 0.50 cc/cycle

MANIFOLD TYPE : M

Outlet Ports	Part Number	Dimensions		Weight	Bar Profile
		A	B		
1	6265	40	20	21	
2	6266	61	41	33	
3	6267	82	62	44	
4	6268	103	83	58	
5	6269	124	104	68	
6	6274	145	125	80	
7	6276	166	146	92	
8	6239	187	167	104	

Double Row

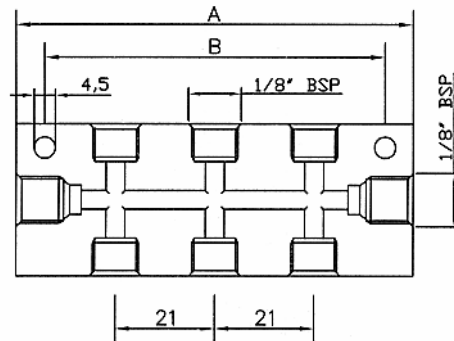

MANIFOLD TYPE : P

Outlet Ports	Part Number	Dimensions		Weight	Bar Profile
		A	B		
2	6236	40	20	28	
4	6237	61	41	41	
6	6238	82	62	60	
8	6188	103	83	71	
10	6189	124	104	90	
12	6210	145	125	101	

For Injectors 0.03 – 1.00 cc/cycle

MANIFOLD TYPE : L

Outlet Ports	Part Number	Dimensions		Weight	Bar Profile
		A	B		
1	3071311	42	20	30	
2	3071312	63	41	63	
3	3071313	84	62	96	
4	3071314	105	83	120	
5	3071315	126	104	146	
6	3071316	147	125	169	

MANIFOLD TYPE : N

Outlet Ports	Part Number	Dimensions		Weight	Bar Profile
		A	B		
2	3071322	42	30	90	
4	3071324	63	51	120	
6	3071326	84	72	140	
8	3071328	105	93	180	

Extruded Bar Profiles (available also for Custom Manifolds)

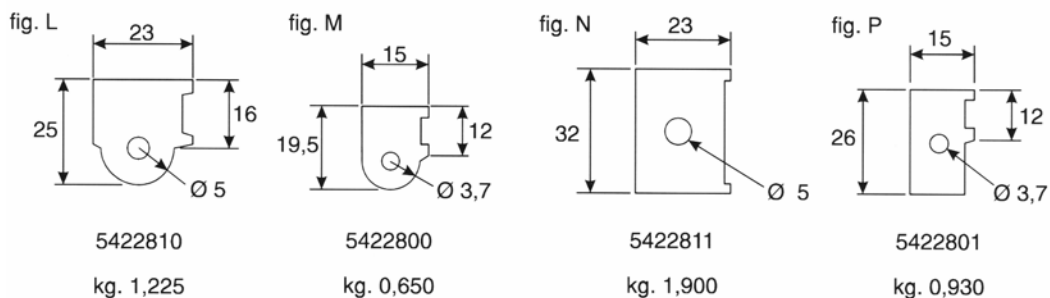

33V – System 33 Injectors

**Manifolds – Type W : for Backward Compatibility with existing systems.
For Injectors : 0.03 to 0.16 cc/cycle.**

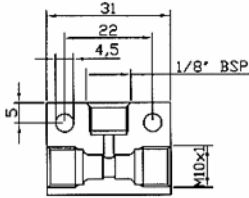

1 Outlet

Part Number: 3071301

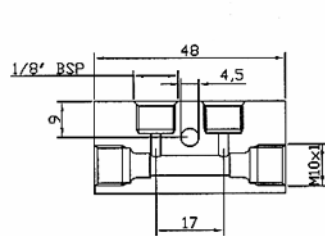

2 Outlets

Part Number: 3071302

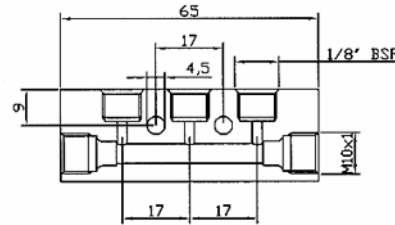

3 Outlets

Part Number: 3071303

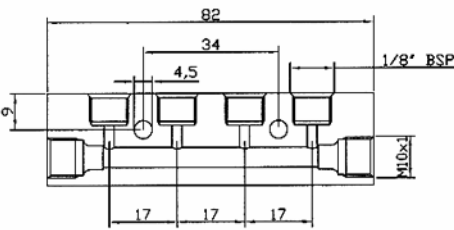

4 Outlets

Part Number: 3071304

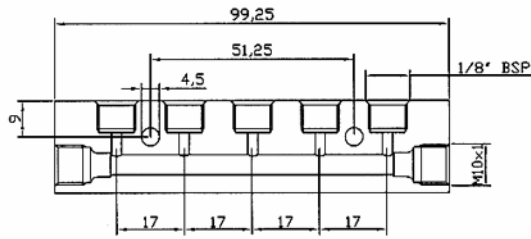

5 Outlets

Part Number: 3071305

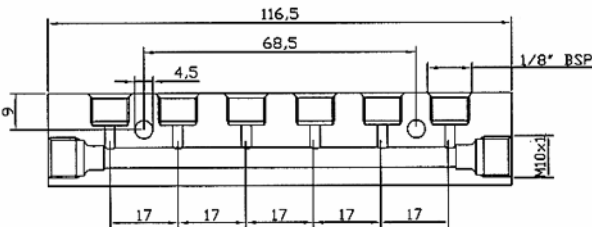

6 Outlets

Part Number: 3071306

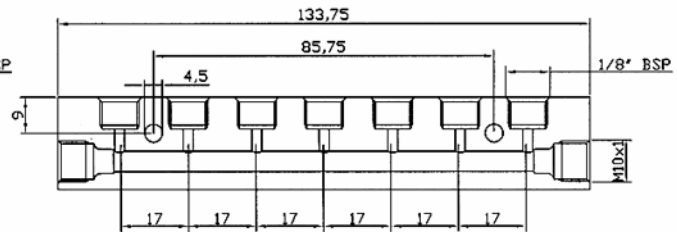

7 Outlets

Part Number: 3071307

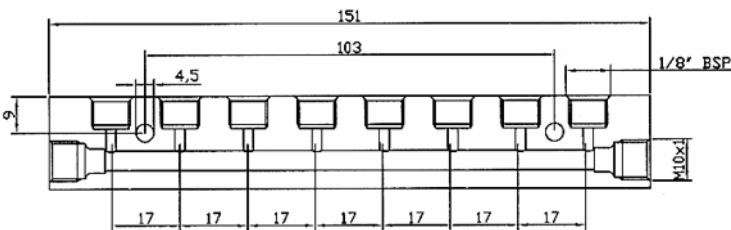

8 Outlets

Part Number : 3071308

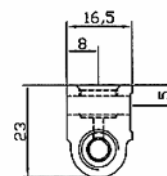

Profile

Manifolds – Single Row stainless steel Aisi 304

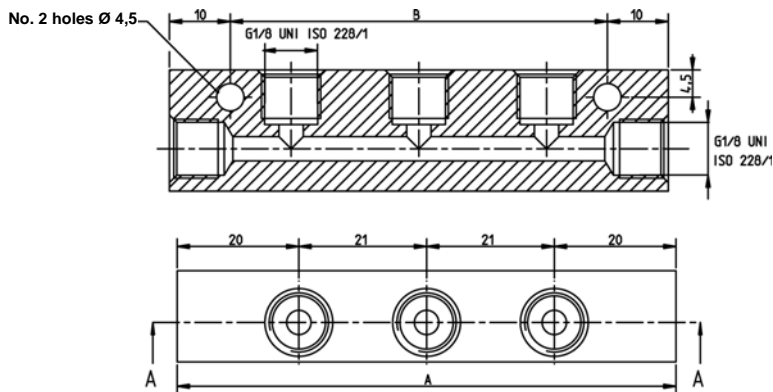

Outlet Ports	Part Number	Dimensions		Bar Profile
		A	B	
1	520101	40	20	
2	520102	61	41	
3	520103	82	62	
4	520104	103	83	
5	520105	124	104	
6	520106	145	125	
7	520107	166	146	
8	520108	187	167	

Manifolds – Single Row for DIN 3852 Fittings (Aluminium)

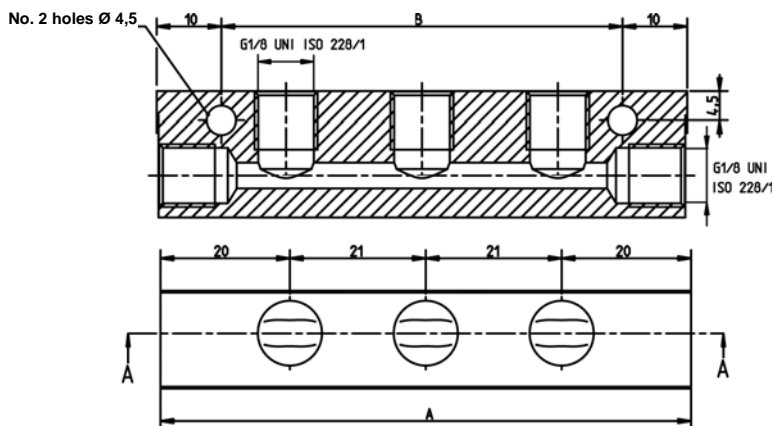

Outlet Ports	Part Number	Dimensions		Bar Profile
		A	B	
1	6901	40	20	
2	6902	61	41	
3	6903	82	62	
4	6904	103	83	
5	6905	124	104	
6	6906	145	125	
7	6907	166	146	
8	6908	187	167	

Manifold – Double Row for DIN 3852 Fittings (Aluminium)

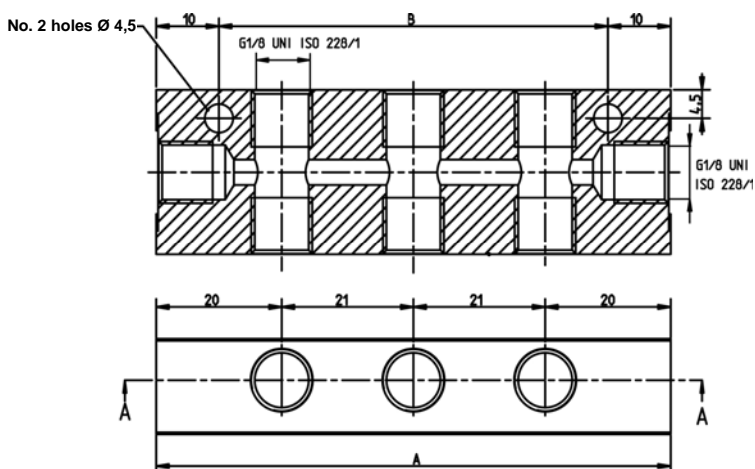

Outlet Ports	Part Number	Dimensions		Bar Profile
		A	B	
2	6911	40	20	
4	6912	61	41	
6	6913	82	62	
8	6914	103	83	
10	6915	124	104	
12	6916	145	125	

Metalling tube

Material	Sizes	Part Number	Weight Kg/ml	Pressure		Bushes for tubes
				bar	Psi	
Copper plated steel pipe	Ø 4 x 0.71 in bars	5118000	0.060	500	7120	-
	Ø 6 x 0.71 in bars	5118001	0.097	310	4400	-
	Ø 8 x 0.71 in bars	5118002	0.134	220	3130	-
Annealed copper tube	Ø 4 x 0.5 in coils	5501201	0.049	133	1900	-
	Ø 6 x 1 in coils	5501203	0.140	200	2850	-
	Ø 8 x 1 in coils	5501204	0.196	130	1850	-

N.B. Drawn steel and annealed copper tubes must be ordered in kg. Copper plated steel pipes in meters.

Nylon tube

Material	Sizes	Part Number	Weight Kg/m	Pressure bar	Temperature °C	Bushes for tubes
Nylon tube (L. P.)	Ø 4 x 3 in coils	5717300	0.006	45	0 ÷ +100	3008117
Nylon tube (L. P.)	Ø 6 x 4,5 in coils	5717301	0.014	25	-40 ÷ +80	3008116
Nylon tube (L. P.)	Ø 8 x 6 in coils	5717302	0.025	50	0 ÷ +100	3008114
Nylon tube (H. P.)	Ø 4 x 2,5 in coils	5717202	0.008	80	0 ÷ +100	0201359
Nylon tube (H. P.)	Ø 6 x 4 in coils	5717203	0.017	66	0 ÷ +100	0201360
Nylon tube (H. P.)	Ø 8 x 5 in coils	5717204	0.034	80	0 ÷ +100	0201361

Pipe Clips

Pipe clips with one fixing hole



Part No.	Description	Self-tapping screw		Self-threading rivet	
		Part No.	Description	Part No.	Description
0111151	Tube Ø 4 - Mount Ø 4.5	0014352	M3, L. 8	0018065	Ø 3.5, L. 8
0111201	Tube Ø 6 - Mount Ø 5	0014355	M4, L. 10	0018067	Ø 4.2, L. 9.5
0111251	Tube Ø 8 - Mount Ø 5	0014355	M4, L. 10	0018067	Ø 4.2, L. 9.5
0111152	2 Tubes Ø 4 – Mount Ø 4.5	0014352	M3, L. 8	0018065	Ø 3.5, L. 8
0111153	3 Tubes Ø 4 – Mount Ø 4.5	0014352	M3, L. 8	0018065	Ø 3.5, L. 8

Pipe clips with two fixing hole





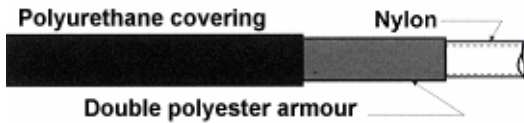

Part No.	Description	Self-tapping screw		Self-threading rivet	
		Part No.	Description	Part No.	Description
0111154	4 Tubes Ø 4 – Mount Ø 4.5	0014352	M3, L. 8	0018065	Ø 3.5, L. 8
0111155	5 Tubes Ø 4 – Mount Ø 4.5	0014352	M3, L. 8	0018065	Ø 3.5, L. 8
0111156	6 Tubes Ø 4 – Mount Ø 4.5	0014352	M3, L. 8	0018065	Ø 3.5, L. 8
0111158	8 Tubes Ø 4 – Mount Ø 5	0014352	M3, L. 8	0018065	Ø 3.5, L. 8
0111202	2 Tubes Ø 6 – Mount Ø 5	0014355	M4, L. 10	0018067	Ø 4.2, L. 9.5
0111203	3 Tubes Ø 6 – Mount Ø 5	0014355	M4, L. 10	0018067	Ø 4.2, L. 9.5
0111204	4 Tubes Ø 6 – Mount Ø 5	0014355	M4, L. 10	0018067	Ø 4.2, L. 9.5
0111205	5 Tubes Ø 6 – Mount Ø 5	0014355	M4, L. 10	0018067	Ø 4.2, L. 9.5
0111252	2 Tubes Ø 8 – Mount Ø 5	0014355	M4, L. 10	0018067	Ø 4.2, L. 9.5
0111253	3 Tubes Ø 8 – Mount Ø 5	0014355	M4, L. 10	0018067	Ø 4.2, L. 9.5
0111254	4 Tubes Ø 8 – Mount Ø 5	0014355	M4, L. 10	0018067	Ø 4.2, L. 9.5
0111255	5 Tubes Ø 8 – Mount Ø 5	0014355	M4, L. 10	0018067	Ø 4.2, L. 9.5

Nylon hoses with reusable fittings

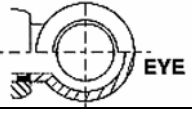

Tube only Part No.	Ø tube		Minimum bend radius mm	Working pressure		Weight Kg
	External mm	Internal mm		bar	psi	
3362026	8	4	38	200	2900	0.050
3362023	12,7	6,4	51	250	3625	0.107

Fittings	Part No.	For tube Ø ext.	Thread	Straight tube Ø	Swivel	Part No.	For tube Ø ext.	Thread
 Solid male with cylindrical thread	3084393	8	1/8" Gas	-	 EYE	3084395	8	-
	3084421	13	1/4" Gas	-		3084409	13	-
 Straight tube	3084424	8	-	4	 Fitting	3084408	8	1/8" Gas
	3084422	8	-	6		308410	13	1/4" Gas
	3084425	13	-	6				
	3084385	13	-	8				
 90° swivel female	3084423	8	1/8" Gas	-	 Nipple connector	0102620	-	1/8" Gas
	3084386	13	M14x1,5	-		0102621	-	1/4" Gas

Special hoses

Working pressure: 250 bar (3675 psi)
 Bursting pressure: 1000 bar (14700 psi)
 Minimum bend radius: 45 mm (1.77 in.)

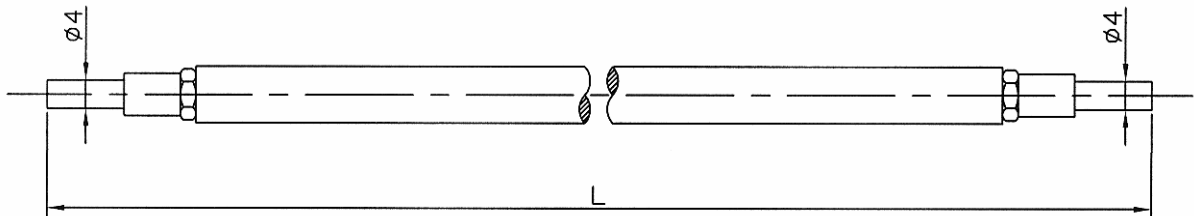

Part No.	Tube only Part No.	Length (mm)
3362058	3362026	400
3362052	3362026	430
3362059	3362026	450
3362060	3362026	500
3362053	3362026	520
3362055	3362026	550
3362054	3362026	600
3362057	3362026	650
3362062	3362026	680
3362056	3362026	750
3362063	3362026	920

High pressure Push-in for oil and grease

Material: Brass
 Working pressure: 0 – 150 bar (0 – 2175 psi)
 Working temperature: -10°C - +80°C

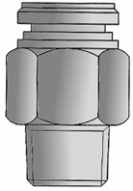

Straight terminal

Part No.	Ø Tube	Thread	Hex
3084577	4	1/8" Gas	10
3084578	6	1/8" Gas	13
3084579	4	M6 x 1	10
3084586	4	1/8" NPT	10
3084587	6	1/8" NPT	13

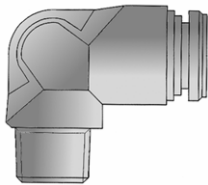

90° terminal

Part No.	Ø Tube	Thread	Hex
3084580	4	1/8" Gas	9
3084581	6	1/8" Gas	11
3084588	4	1/8" NPT	9
3084589	6	1/8" NPT	11

Available in packages 25 pieces each.

Dropsa

 **Dropsa USA Inc.**
 50679 Wing Drive
 Utica, Michigan 48315, USA
 Tel: (+1) 586-566-1540
 Fax: (+1) 586-566-1541
 E-mail: salesusa@dropsa.com

 **Dropsa (UK) Ltd**
 Unit 6, Egham Business Village,
 Egham, Surrey, TW20 8RB
 Tel: (+44) 01784 - 431177
 Fax: (+44) 01784 - 438598
 E-mail: salesuk@dropsa.com

 **Dropsa S.p.A.**
 Via B. Croce, 1
 20090 Vimodrone (MI) Italy.
 Tel: (+39) 02 - 250.79.1
 Fax: (+39) 02 - 250.79.767
 E-mail: sales@dropsa.it (Export)
 E-mail: vendite@dropsa.it (National)

 **Dropsa GmbH**
 Volmerswerther Strasse 80
 40221 Dusseldorf 1, Germany
 Tel: (+49) 0211-394-011
 Fax: (+49) 0211-394-013
 E-mail: sales@dropsa.de

 **Dropsa France**
 23, Av. des Morillons
 Z.I. des Doucettes
 95140 - Garges Les Gonesse
 Tel: (+33) 01-39-93-00-33
 Fax: (+33) 01-39-86-26-36
 E-mail: sales@dropsa.com

 **Dropsa do Brazil**
 Rua Sobralia 175/866
 Sao Paulo
 Tel: (+55) 011-563-100-07
 Fax: (+55) 011-563-194-08
 E-mail: salesbr@dropsa.com

 **Polydrop S.A.**
 Av. Fabregada 26 - Pje Est.2
 08907 L'Hospitalet de Llobregat
 Barcelona, Spain
 Tel: (+34) 93-26-022-50
 Fax: (+34) 93-26-022-51
 E-mail: sales@dropsa.it

 **Dropsa Australia Pty.**
 C20/148 Old Pittwater Road
 Brookvale NSW 2100
 Tel: (+61) 02-9938-66-44
 Fax: (+61) 02-9938-66-11
 E-mail: sales@dropsa.com

Scheme of new codification

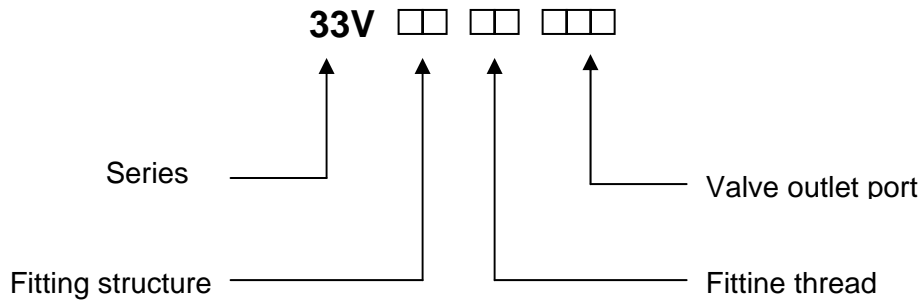

Example: 33V IS M5 003

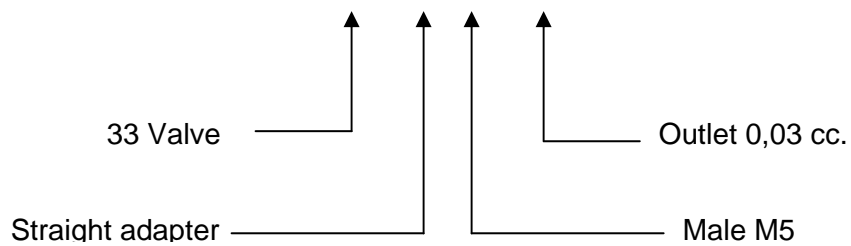

Fitting structures abbreviations

Description	Abbreviation
Straight adapter	IS
L Adapter	LN
L Adapter with rotary connection port	LC
T Adapter	TN
T Adapter with rotary connection port	TC
C Adapter	CN
C Adapter with rotary connection port	CC
E Adapter	EN
E Adapter with rotary connection port	EC
X Adapter	XN
X Adapter with rotary connection port	XC



Dropsa

18.11



www.dropsa.com

WK 36/06
C2032IE